



Lenses

CS 6334 Virtual Reality

Professor Yu Xiang

The University of Texas at Dallas

Some slides of this lecture are based on the Virtual Reality textbook by Steven LaValle

Review of VR Systems

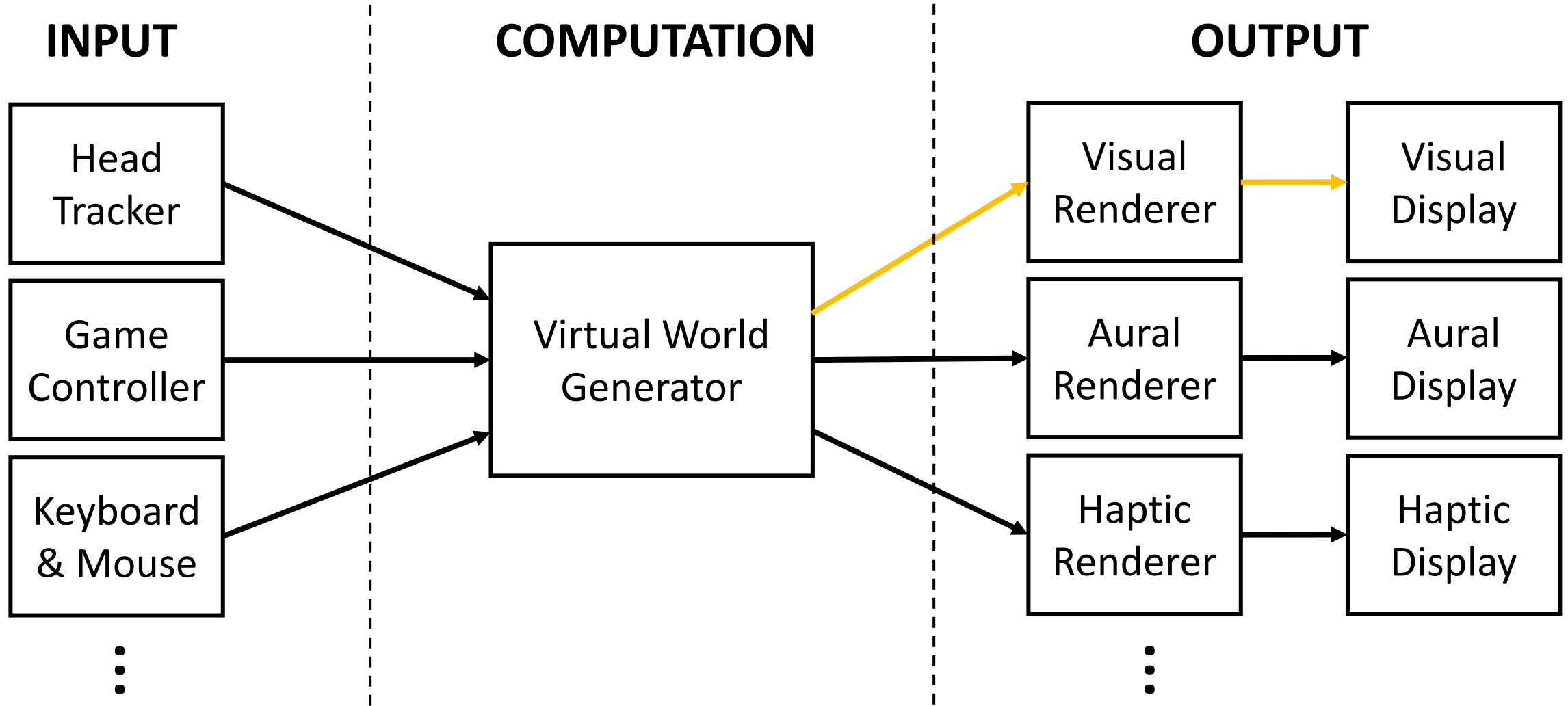

Aperture Size of Pinhole Camera

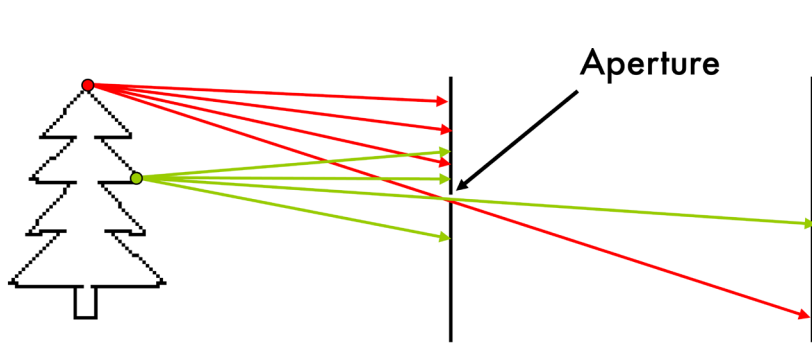

Shrinking
aperture
size

What happen if the aperture is too small?

- Less light passes through
- Adding lenses

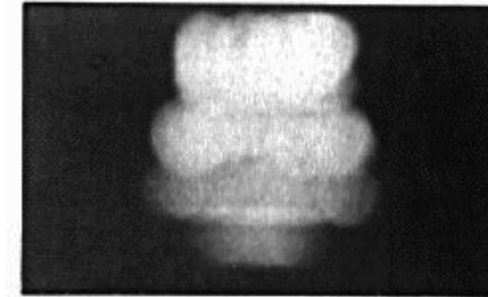
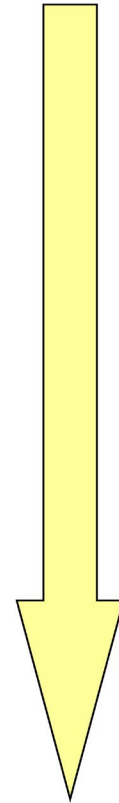

2 mm

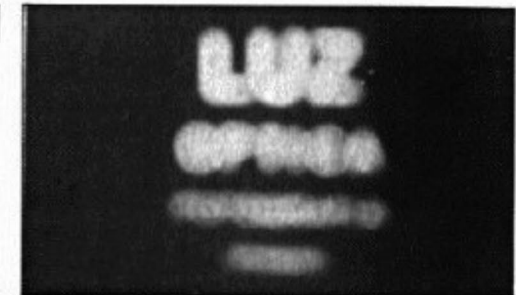

1 mm



0.6mm



0.35 mm

Lenses

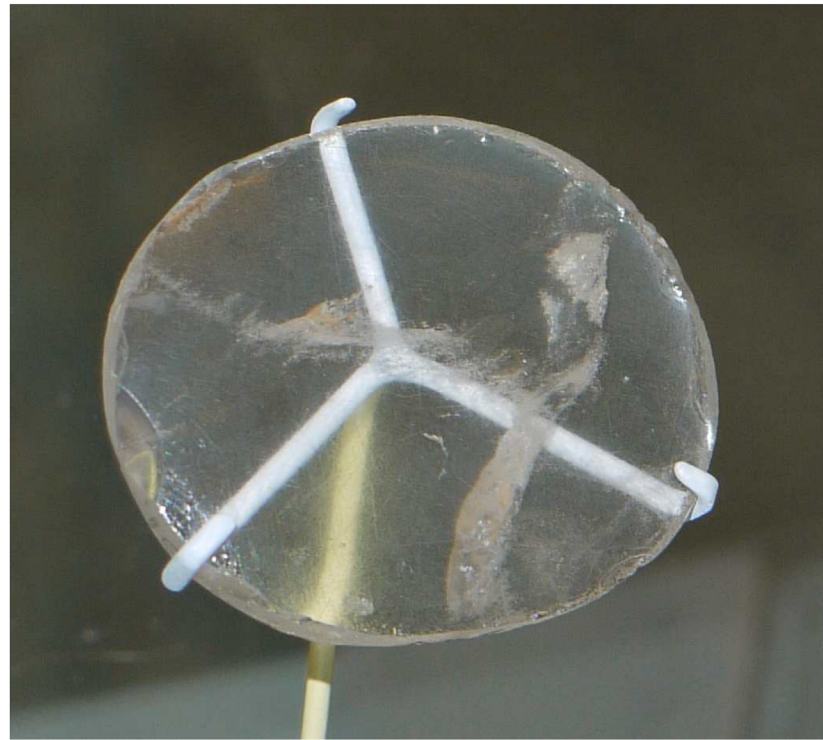

(a)



(b)

Figure 4.8: (a) The earliest known artificially constructed lens, which was made between 750 and 710 BC in ancient Assyrian Nimrud. It is not known whether this artifact was purely ornamental or used to produce focused images. Picture from the British Museum. (b) A painting by Conrad von Soest from 1403, which shows the use of reading glasses for an elderly male.

Snell's Law

- How much rays of light bend when entering and exiting a transparent material

- Refractive index of a material $n = \frac{c}{s}$

- Air $n = 1.000293$, water $n = 1.33$

- Crown glass $n = 1.523$

- Snell's Law

$$n_1 < n_2$$

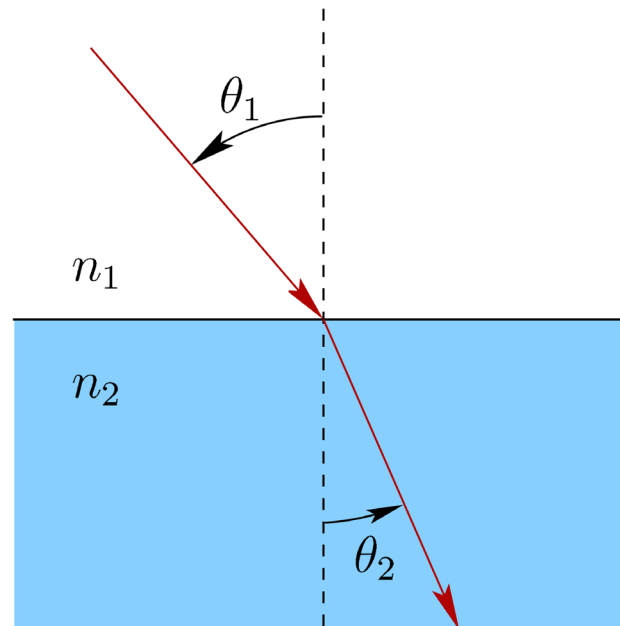

c ← Speed of light in a vacuum

s ← Speed of light in the medium

$$n_1 \sin \theta_1 = n_2 \sin \theta_2$$

$$\theta_2 = \sin^{-1} \left(\frac{n_1 \sin \theta_1}{n_2} \right)$$

Convex Lenses

- Prisms

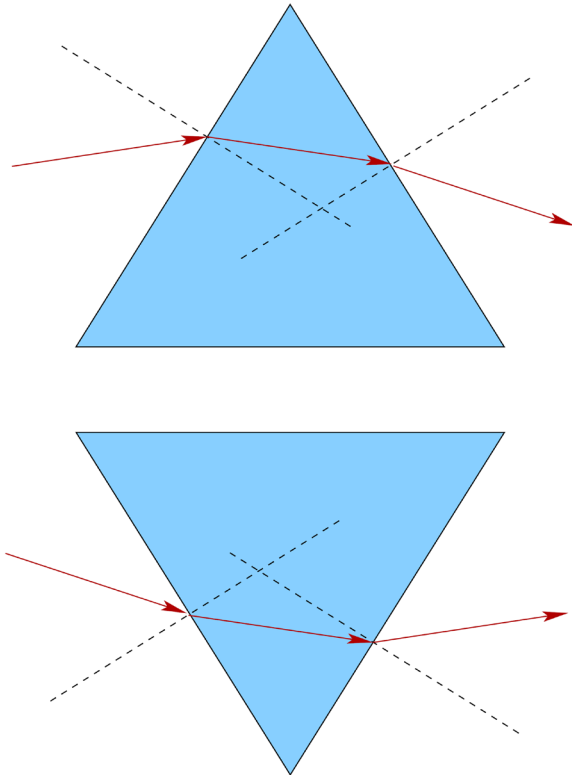

- A simple convex lens

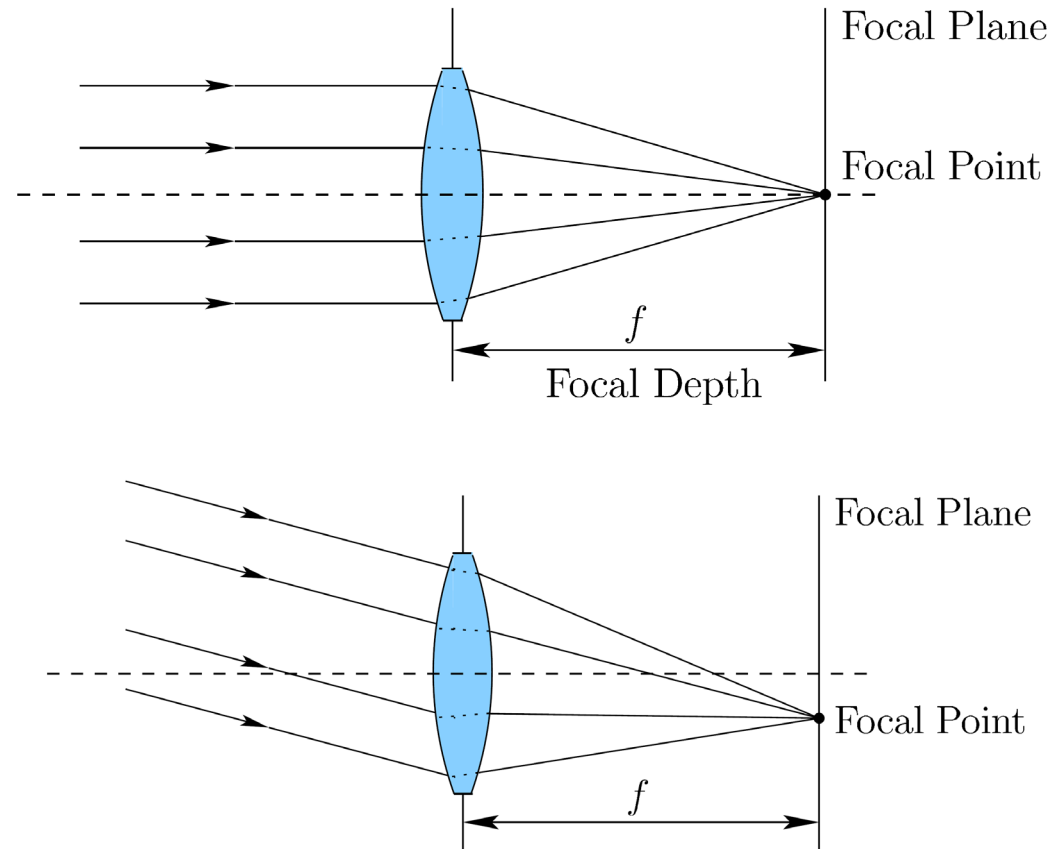

Convex Lenses

- Objects in distance
 - Cameras

$$\frac{1}{s_1} + \frac{1}{s_2} = \frac{1}{f}$$

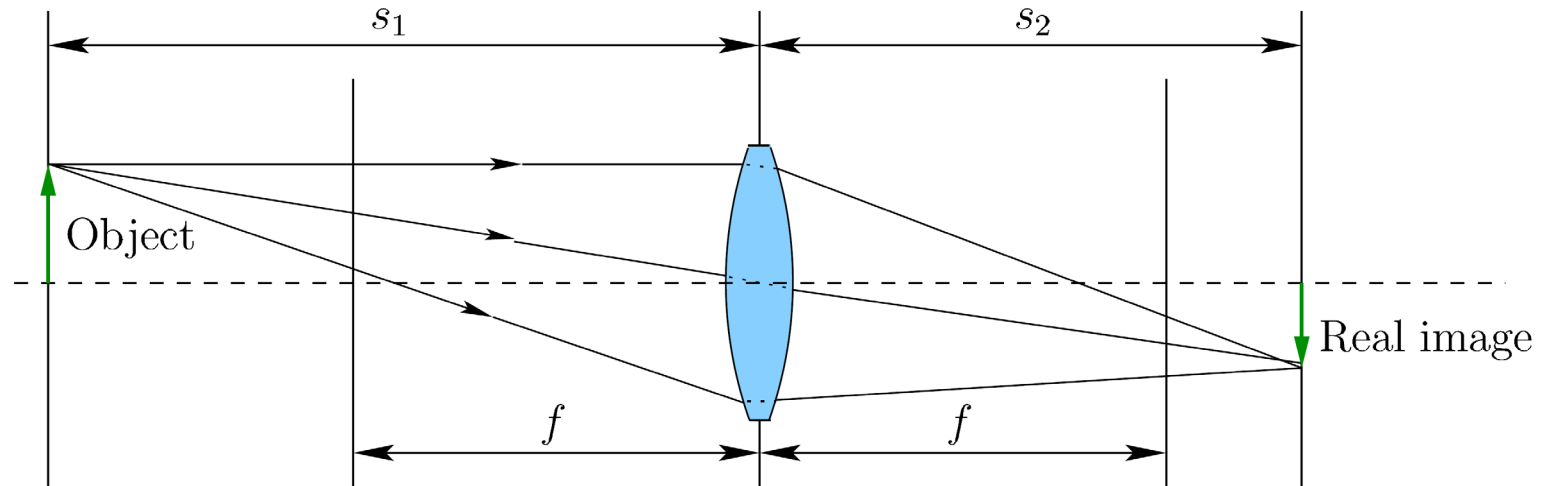

- Objects very close
 - Magnification
 - VR headsets

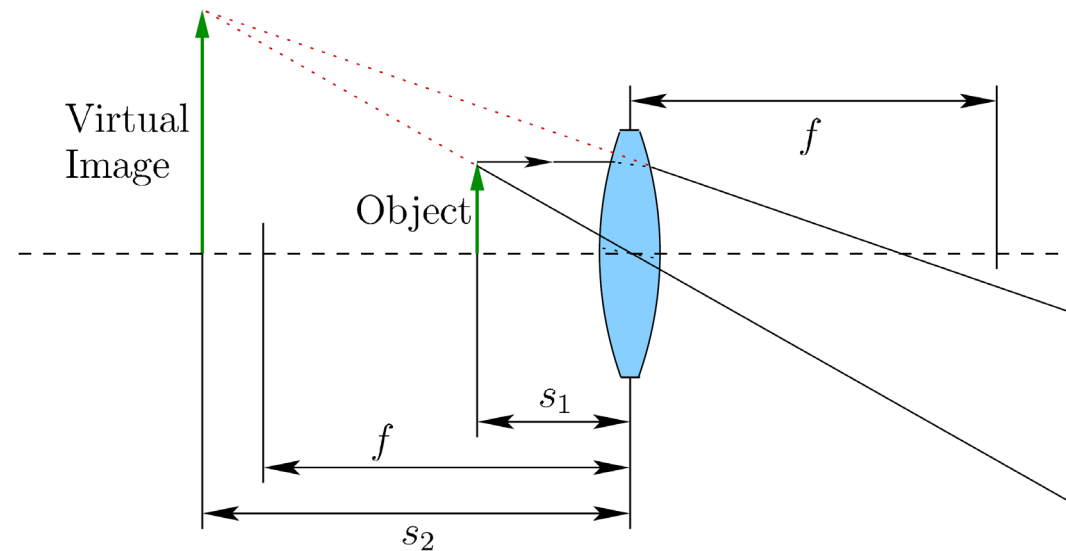

Controllable Aperture

- In the pinhole case, all depths are “in focus”, but there may not be enough light
- When using a convex lens, it focuses objects at a single depth

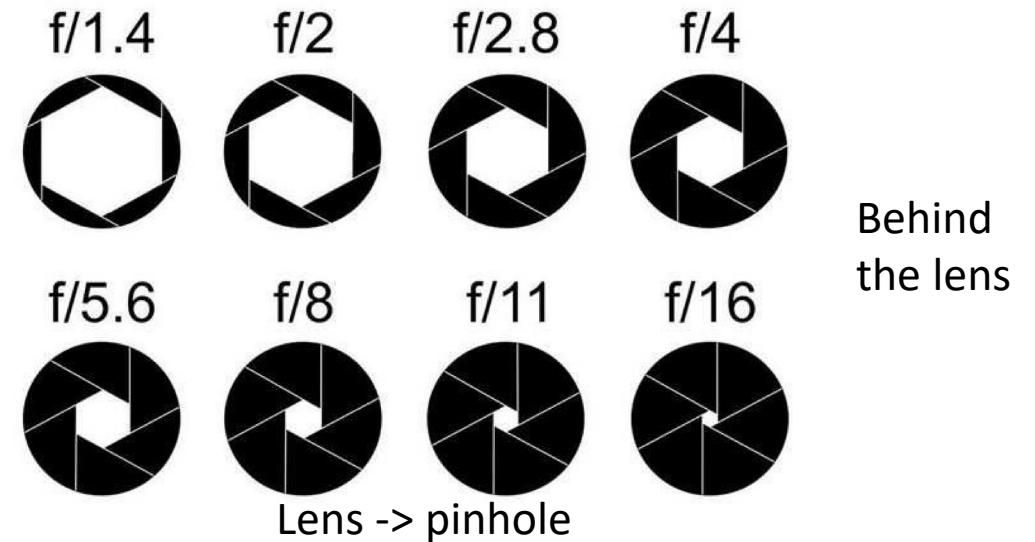
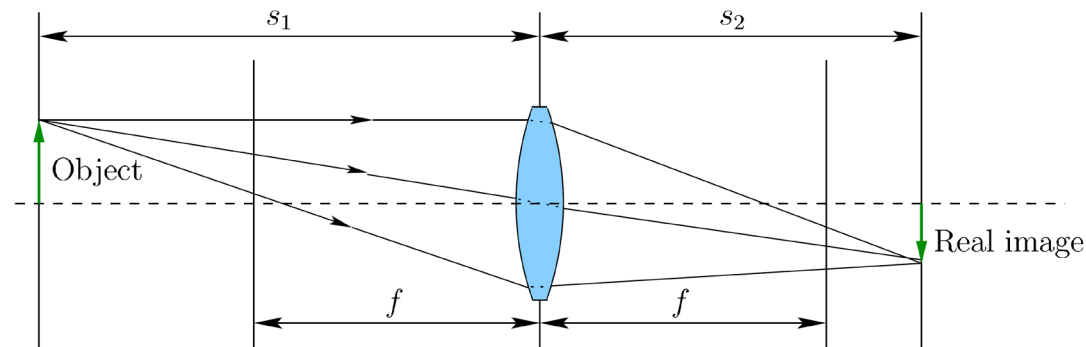
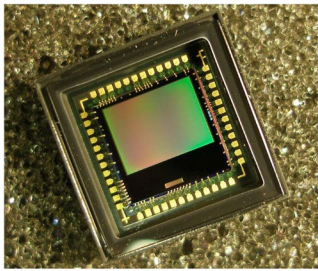

Figure 4.34: A spectrum of aperture settings, which control the amount of light that enters the lens. The values shown are called the *focal ratio* or *f-stop*.

Shutters

- Collecting photons for each pixel



CMOS sensors

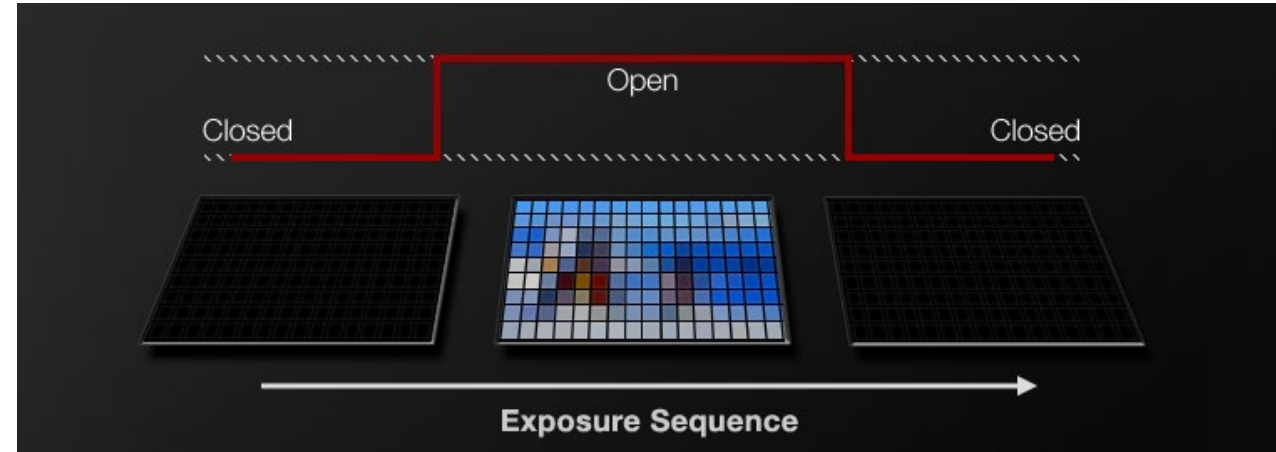

- Rolling shutter vs. Global shutter

Rolling Shutter

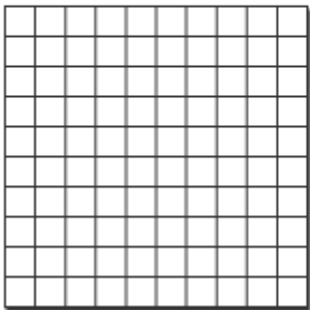

Global shutter

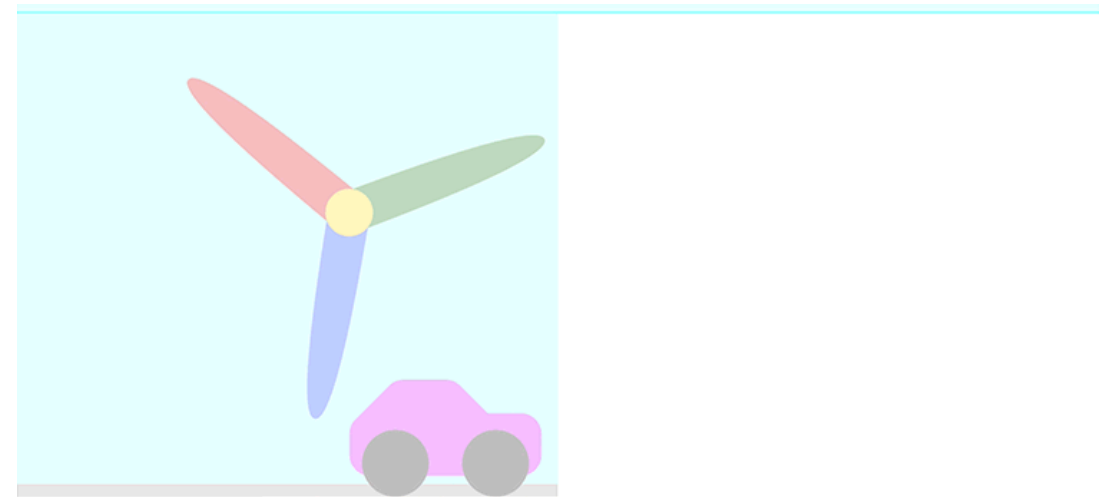
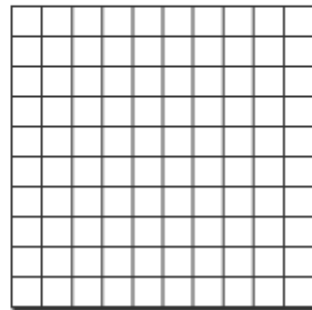

Rolling shutter

Chromatic Aberration

- The speed of light through a medium depends on the wavelength
 - Solution: combining convex and concave lenses of different materials

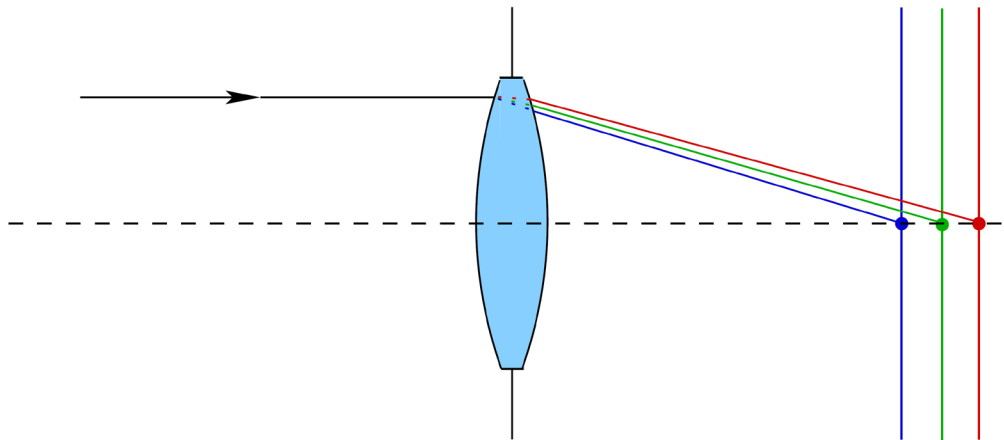

Figure 4.17: Chromatic aberration is caused by longer wavelengths traveling quickly through the lens. The unfortunate result is a different focal plane for wavelength or color.



Figure 4.18: The upper image is properly focused whereas the lower image suffers from chromatic aberration. (Figure by Stan Zurek, license CC-BY-SA-2.5.)

Spherical Aberration

- Rays further away from the lens center being refracted more than rays near the center

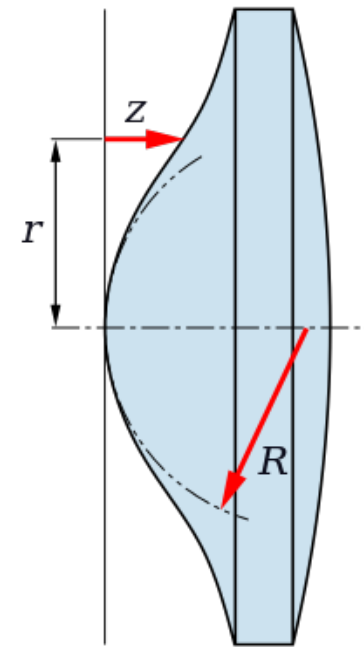
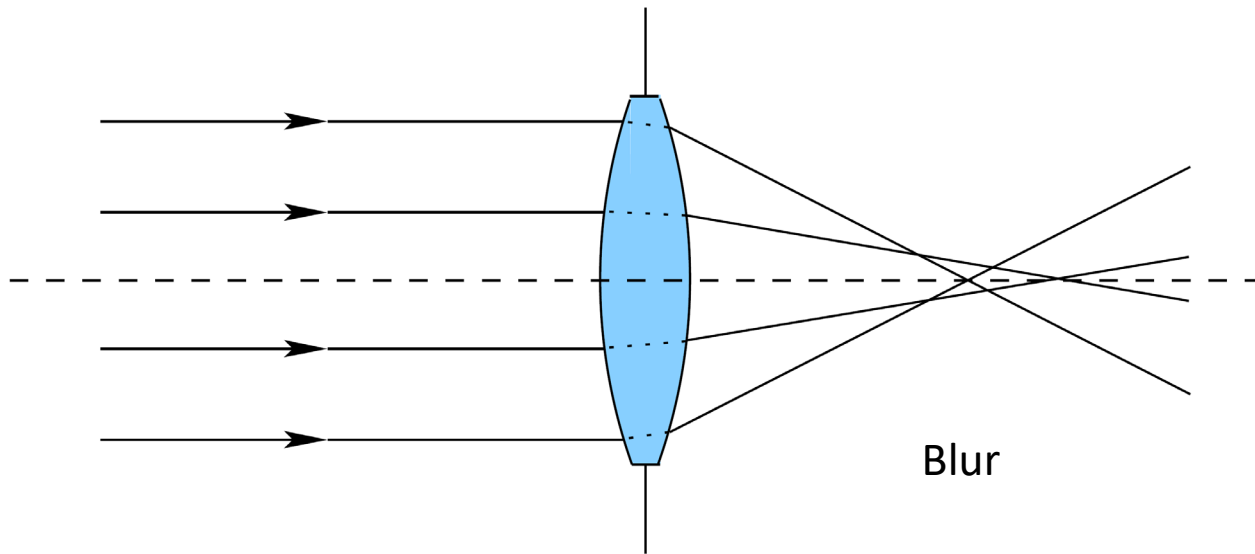

Aspheric lens

Optical Distortion

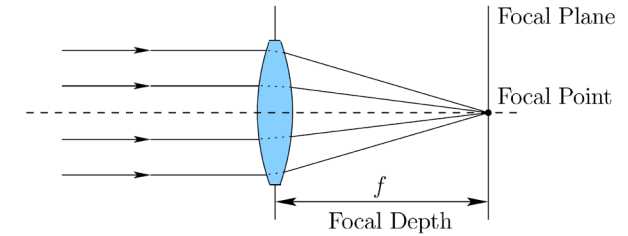

- The variation of refractive index towards the outer extremities of a rotational symmetric lens can cause magnification changes in the image space, depending on the distance from the principal axis.

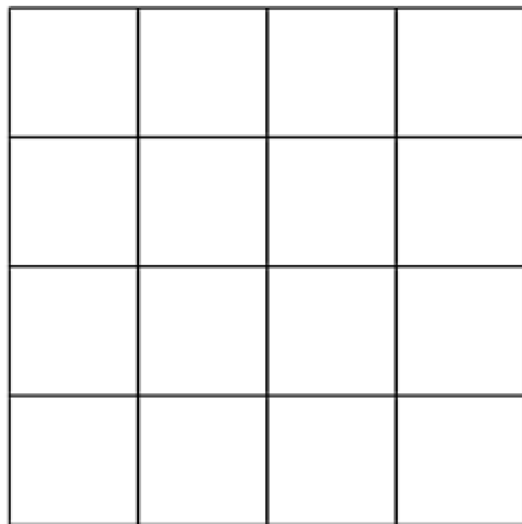

No distortion

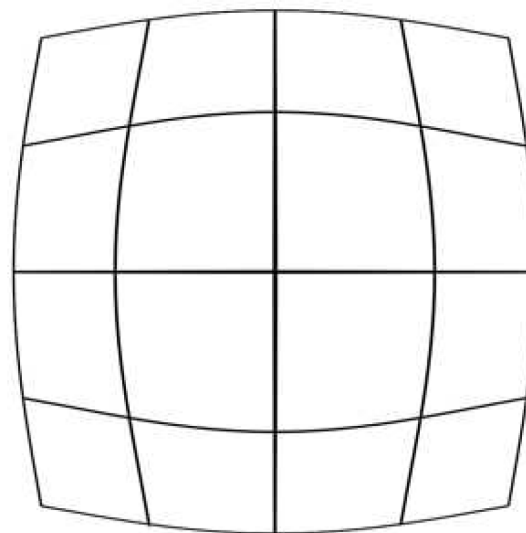

Barrel distortion
(wide-angle lenses)

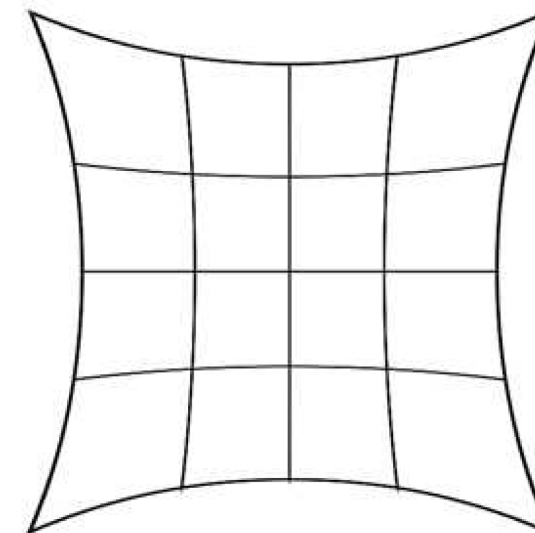

pincushion distortion
(telephoto-lenses)

Angular Field of View (AFOV)

$$\text{AFOV} = 2 \times \tan^{-1} \left(\frac{H}{2f} \right)$$

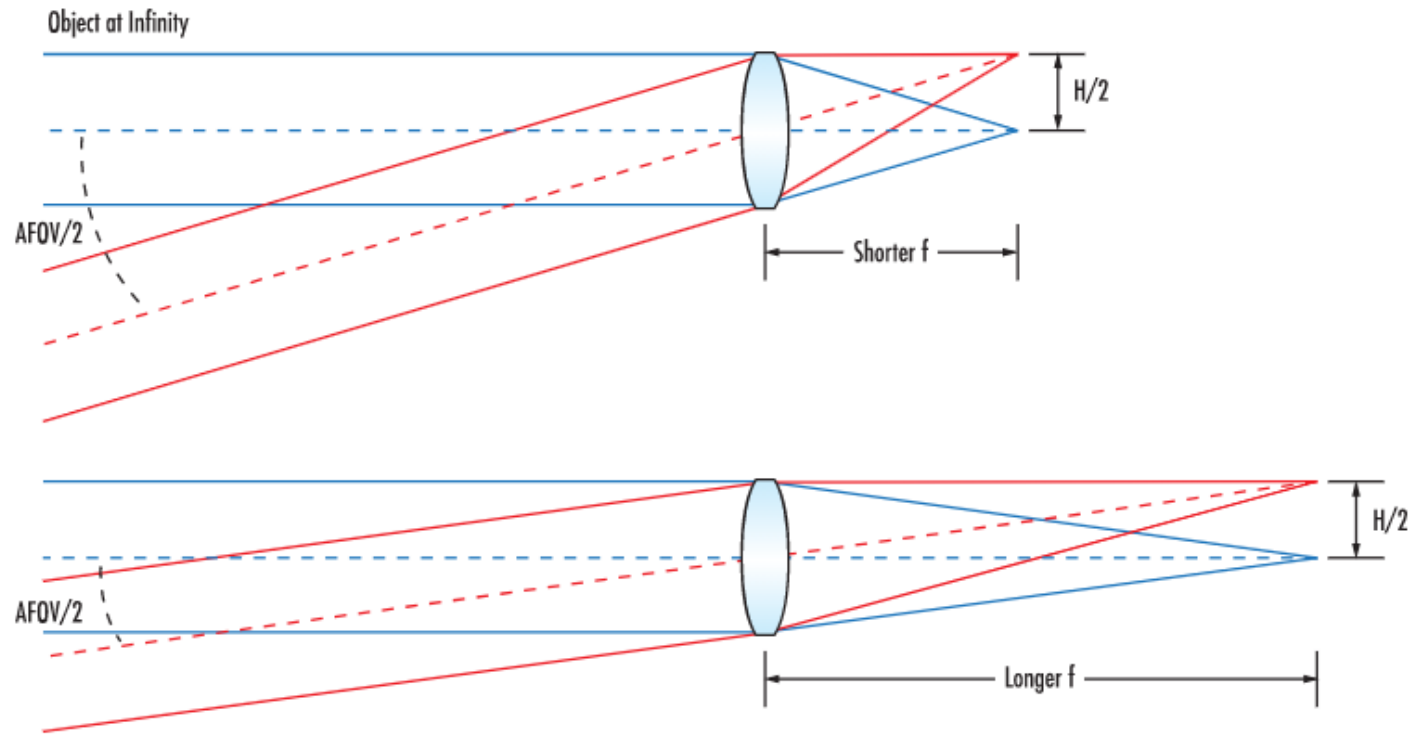

Figure 1: For a given sensor size, H , shorter focal lengths produce wider AFOV's.

Barrel distortion
(wide-angle lenses)

pincushion distortion
(telephoto-lenses)

Barrel Distortion of Fisheye Cameras



Figure 4.21: An image with barrel distortion, taken by a fish-eyed lens. (Image by Wikipedia user Ilveon.)

Tangential Distortion

- Camera sensor mis-alignment during the manufacturing process

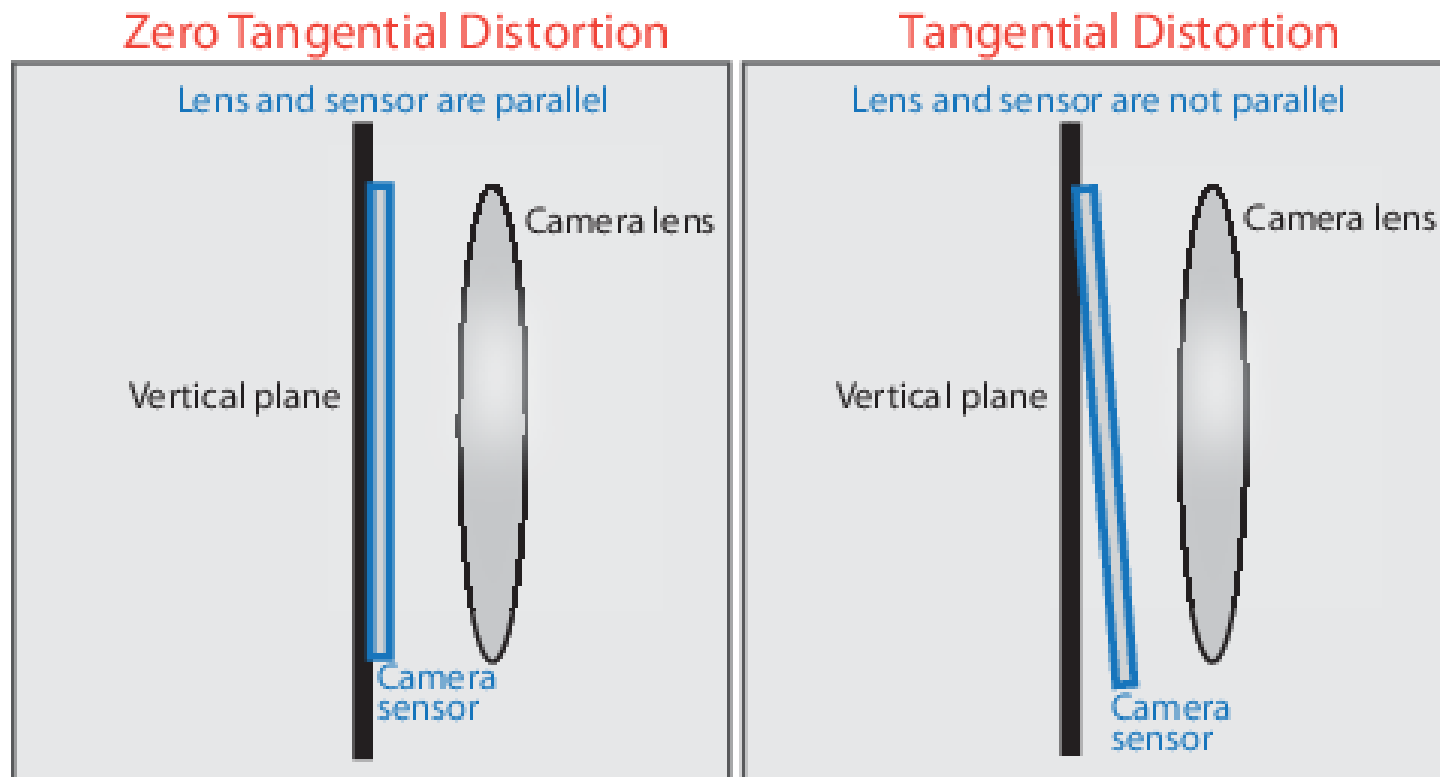

Distortion Correction

- The Brown-Conrady distortion model [Wikipedia]

$$\begin{aligned}x_u &= x_d + (x_d - x_c)(K_1 r^2 + K_2 r^4 + \dots) + (P_1(r^2 + 2(x_d - x_c)^2) \\ &\quad + 2P_2(x_d - x_c)(y_d - y_c))(1 + P_3 r^2 + P_4 r^4 \dots) \\ y_u &= y_d + (y_d - y_c)(K_1 r^2 + K_2 r^4 + \dots) + (2P_1(x_d - x_c)(y_d - y_c) \\ &\quad + P_2(r^2 + 2(y_d - y_c)^2))(1 + P_3 r^2 + P_4 r^4 \dots),\end{aligned}$$

where

- (x_d, y_d) is the distorted image point as projected on image plane using specified lens;
- (x_u, y_u) is the undistorted image point as projected by an ideal [pinhole camera](#);
- (x_c, y_c) is the distortion center;
- K_n is the n^{th} radial distortion coefficient;
- P_n is the n^{th} tangential distortion coefficient; and
- $r = \sqrt{(x_d - x_c)^2 + (y_d - y_c)^2}$, the [Euclidean distance](#) between the distorted image point and the distortion center.^[3]

Use calibration tools to estimate these coefficients

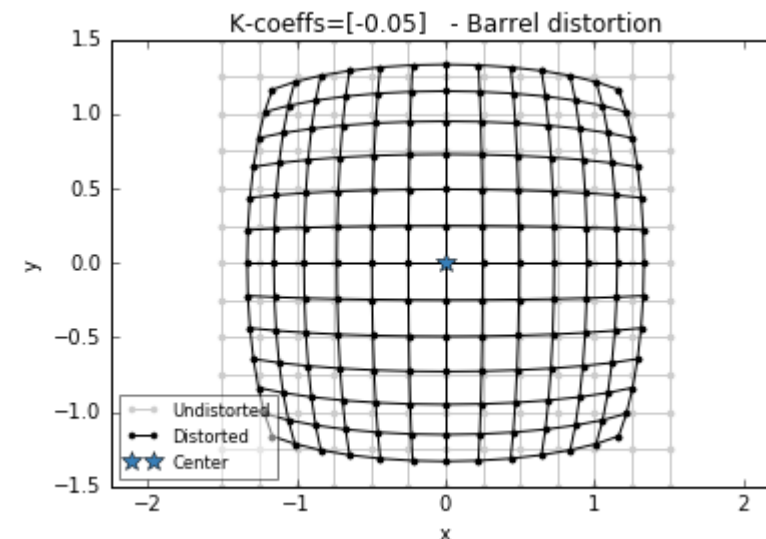

Summary: Camera Models

- Camera projection matrix: intrinsics and extrinsics

$$P = K[R|\mathbf{t}]$$

- Lens distortion
 - Radial distortion coefficients K_1, K_2, K_3, \dots
 - Tangential distortion coefficients P_1, P_2, P_3, \dots

Camera Calibration

- Find the intrinsics, extrinsics and lens distortion coefficients of a camera
- Details will be discussed in CS 6384 Computer Vision
- Chess board camera calibration with OpenCV
https://docs.opencv.org/3.4/dc/dbb/tutorial_py_calibration.html



Further Reading

- Section 4.2, 4.3, Virtual Reality, Steven LaValle
- Image formation by lenses
<https://courses.lumenlearning.com/physics/chapter/25-6-image-formation-by-lenses/>
- Distortion (Wikipedia)
[https://en.wikipedia.org/wiki/Distortion_\(optics\)](https://en.wikipedia.org/wiki/Distortion_(optics))